

1. Absolute Maximum Ratings(Tamb=25°C)

Symbol	Term	Values	Unit
V _S	Supply voltage primary side	18	V
V _{IH}	Input signal voltage(HIGH)	V _S ±0.3	V
I _{outPEAK}	Output peak current	±30	A
I _{outAVmax}	Output average current	±150	mA
f _{max}	Sw itching frequency(max.)	10	kHz
V _{CE}	Collector-emitter voltage	1700	V
dv/dt	Rate of rise and fall of voltage	75	kV/μs
V _{isollO}	Isolation test volt.IN-OUT(1 Min.AC)	4000	V
Q _{out/pulse}	Charge per pulse	±30	μC
T _{top}	Operating temperature (PSHI27W)	-25...+85	°C
T _{stg}	Storage temperature (PSHI27W)	-25...+85	°C
T _{op}	Operating temperature (PSHI 27F)	0...+70 ¹⁾	°C
T _{stg}	Storage temperature (PSHI 27F)	0...+70 ¹⁾	°C

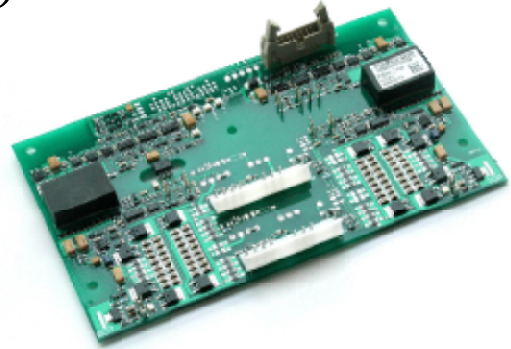

**POWER-SEM
PCB IGBT Driver
PSHI 27W
PSHI 27F**

High Power Double IGBT Driver

2. Electrical Characteristics(Tamb=25°C)

Symbol	Term	Values			Units
		m in.	typ.	max.	
V _S	Supply voltage primary side	14.4	15	15.6	V
I _{SO}	Supply current primary side(no load)	-	250	-	mA
I _S	Supply current primary side(operation)	-	-	700	mA
V _{IT+}	Input threshold voltage(High)	12.9	-	-	V
V _{IT-}	Input threshold voltage(Low)	-	-	2.1	V
R _{in}	Input resistance	-	10	-	kΩ
V _{G(on)}	Turn-on gate voltage output	-	15	-	V
V _{G(off)}	Turn-off gate voltage output	-	-8	-	V
R _{Gon(int)}	Internal gate resistance R _{Gon(int)} per output ²⁾	-	1.1	-	Ω
R _{Goff(int)}	Internal gate resistance R _{Goff(int)} per output ²⁾	-	1.1	-	Ω
R _{GE}	Internal gate-emitter resistance	-	10	-	kΩ
t _{d(on)O}	Input-output turn-on propagation time	-	1+t _{TD}	-	us
t _{d(off)O}	Input-output turn-off propagation time	-	1	-	us
t _{d(Err)}	Error input-output propagation time	-	1	-	us
t _{pRESET}	Error reset time(min.pulse width)	-	5	-	us
t _{pdon-err}	Propagation delay time on error	-	6	-	us
t _{TD}	Top-bottom interlock dead-time	-	10	-	us
V _{CEstat}	Reference voltage for V _{CE} -monitoring	5.3	-	6.3	V
C _{ps}	Coupling capacitance primary-secondary	-	8	-	pF
W	Approx.	150			g
HxBxT	Dimensions	200X120X27			mm

Features

- Dual Driver Circuit for very high power IGBTs
- Suitable for all IGBTs up to 1200V/1700V IGBT
- PSHI 27W with wired signal connection
- PSHI 27F with fibre optic interface
- CMOS(+15V) compatible input buffers
- Soft short circuit turn-off
- Drive interlock top/bottom
- Isolation due to transformers(no opto couplers)
- Supply undervoltage protection(<13V)
- Output connection monitoring by optocoupler
- Error memory/output signal
- Internal isolated power supply

Typical Applications

- Wind generation inverter
- Induction heating power supply
- Chopper
- Inverter
- Communication power supply
- High power UPS

¹⁾ The temperature range is only limited by the signal fibre optic cable: other temperature levels on request

²⁾ External gate input resistor has to be determined by the customer

- I_{outPEAK} per output = I_{outEAK} / n (n: total number of outputs)

- I_{outPEAK} per output has to be considered, when fixing individual values of R_{Gon(int)} and R_{Goff(int)}

- Please note: [R_{Gon(int)} + R_{Goff(int)}] / n ≥ 1.1 Ω

PIN array

Primary Side PIN Array(PSHI27W) X1(14 pin DIN41612)

PIN NO.	Designation	Explanation
2	BOT	input signal bottom switch
3	ERROR	error output,high level active
4	TOP	input signal top switch
8	V _S	supply voltage + 15V
9	V _S	supply voltage + 15V
10	GND	Ground, 0V
11	GND	Ground, 0V

Primary Side PIN Array(PSHI27F) X1(14 pin DIN41612)

PIN NO.	Designation	Explanation
8	V _S	supply voltage + 15V
9	V _S	supply voltage + 15V
10	GND	Ground, 0V
11	GND	Ground, 0V

Secondary Side Pin Array(PSHI27W/PSHI27F) X2; X3

PIN NO.	Designation	Explanation
1	E _{BOT}	emitter output(bottom,switch)
2	G _{BOT}	gate output(bottom switch)
3	C _{ON}	connection control monitoring (jumper in power module necessary)
4	C _{ON}	
7	C _{BOT}	collector output(bottom switch)
8	E _{TOP}	emitter output(top switch)
9	G _{TOP}	gate output(top switch)
12	C _{TOP}	collector output(top switch)

Corresponding relationship between R_{TD} and dead time of jumper J3;K3,J4;K4

R _{TD} sistance value	Dead time
10kΩ	0.9 μs
22kΩ	1.8 μs
33kΩ	2.5 μs
47kΩ	3.2 μs
68kΩ	4 μs
100kΩ	5 μs
330kΩ	7.7 μs
not bridged	10 μs

ATTENTION: The connector leads to the power module should be as short as possible.

Pins place instruction from J3;K3 to J9;K9:

PINs	Functions	Adjustment by factory	Possibilities of functions
J3;K3:TOP J4;K4:BOT	dead time	not bridged: 10us	Refers to Table
J6;K6	R _{CE} TOP	not equipped: 18kΩ	Refers to Fig.1
J7;K7	C _{CE} TOP	not equipped: 330pf	Refers to Fig.1
J8;K8	R _{CE} BOT	not equipped: 18kΩ	Refers to Fig.1
J9;K9	C _{CE} BOT	not equipped: 330pf	Refers to Fig.1

Input Connector,Fibre Optic(Description of LEDs)

for the quick checking of all relevant signals, there are Test-points and LEDs showing the operation.

LED	Signals	Remark
LED TOP	Input TOP	light≈HIGH signal
LED BOT	Input BOT	light≈High signal
LED ERROR	ERROR	light≈ERROR
LED 15V	POWER	light≈POWER ON
LED Connector monitoring	ERROR OUTPUT CONNECTORS	light≈connection ok
LED V _{GE} BOT	GATE BOTTOM	light≈gate signal HIGH
LED V _{GE} TOP	GATE TOP	light≈gate signal HIGH

Deminsions & Pins functions

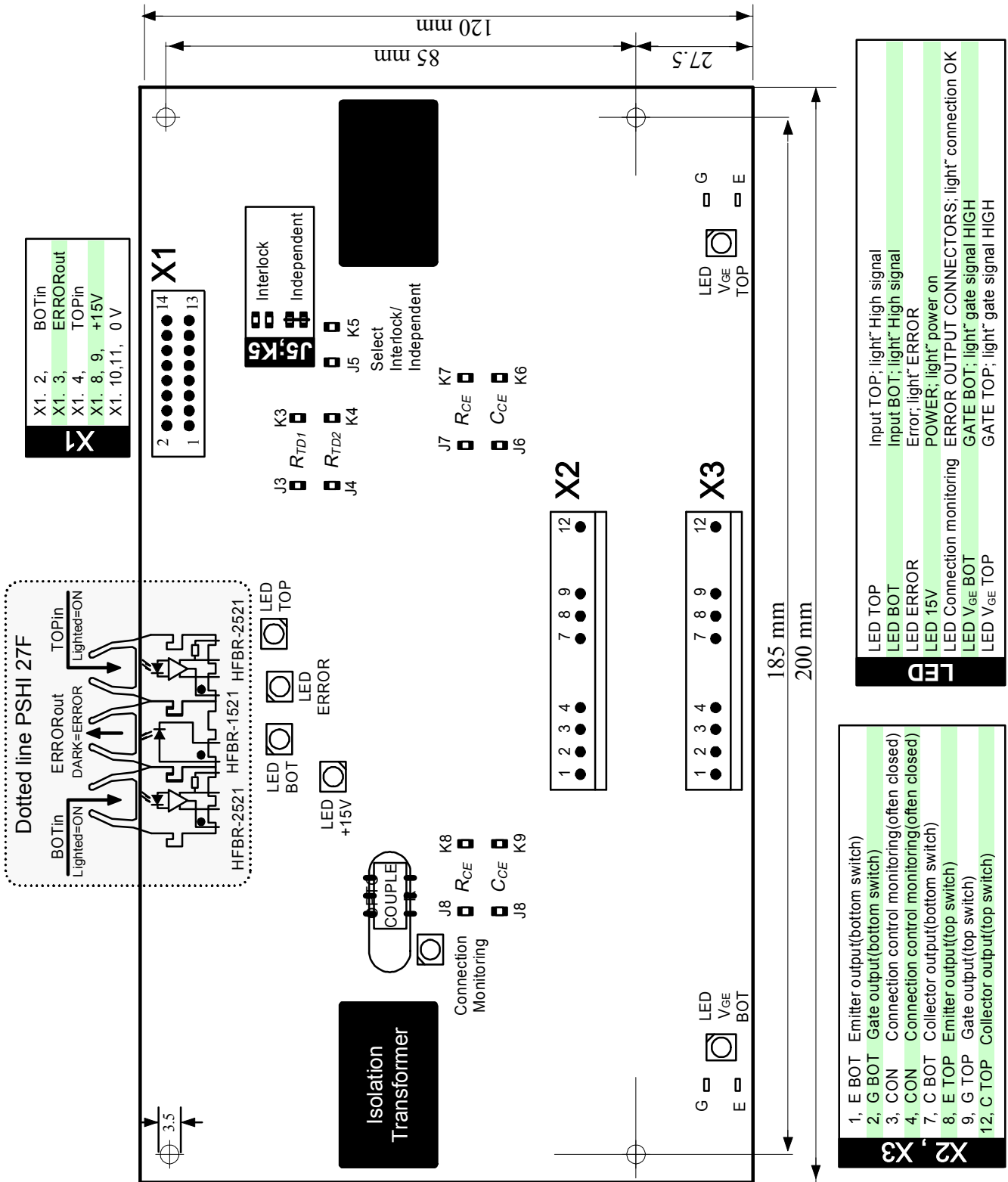

System structure

Fig.2 PSHI 27W

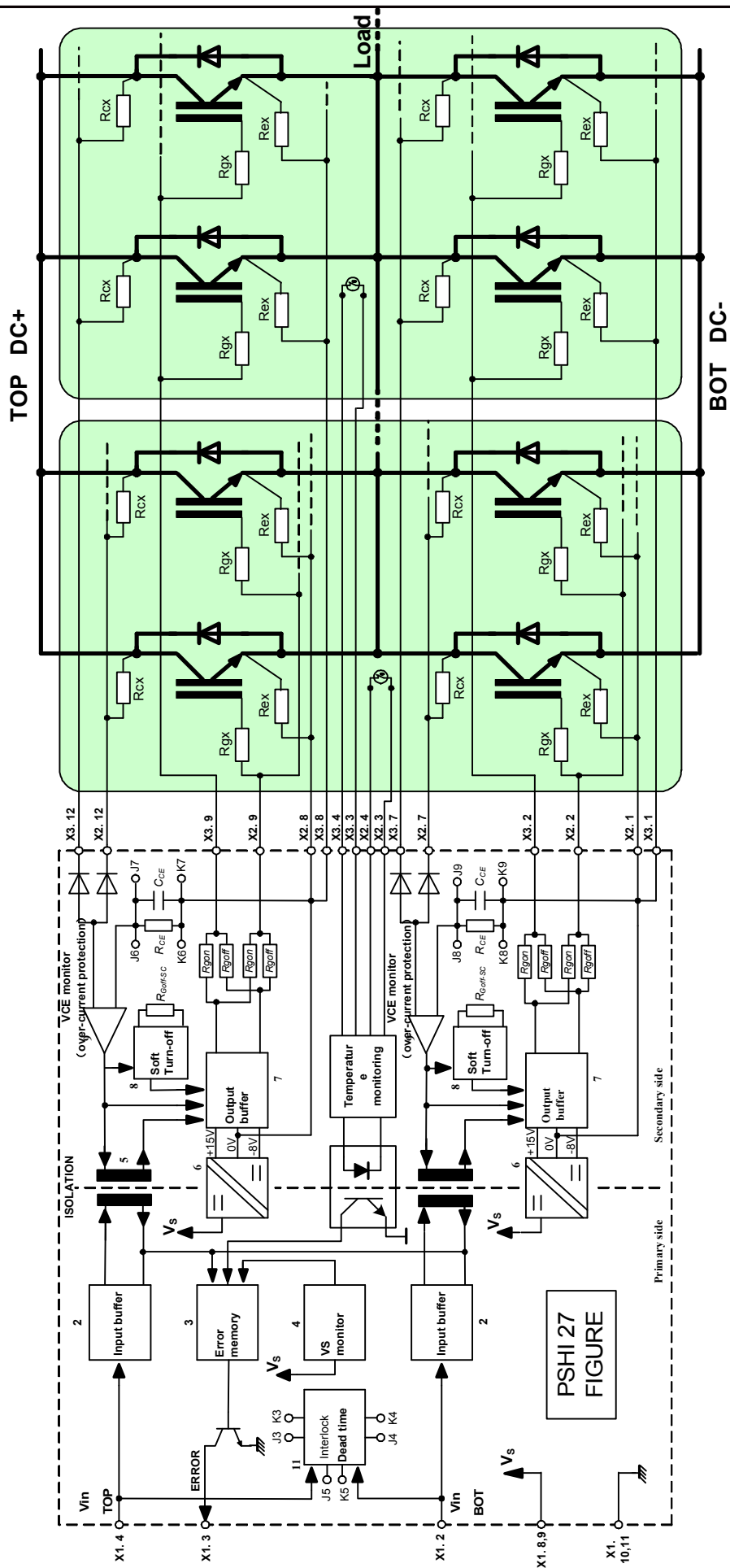

**POWER-SEM DRIVER
PSHI 27 W / PSHI 27 F**

1.Product profile

- 1).The driver comprises short circuit protection for dual IGBTs in half bridge(default 2 pairs, most 4 pairs).If a single IGBT is driven,the non-used output V_{CEin} should be connected to the corresponding E(0V).This is because the non-used V_{CE} monitoring function has to be inhibited.
- 2).Short circuit protection is provided by measuring the V_{CE} voltage. In case of short circuit, the soft turn-off circuit automatically increases the IGBT turn-off time and hence reduces the V_{CE} voltage overshoot to improve the IGBT's reliability.
- 3).The IGBTs are turned on by applying a V_{GEON} of +15V; V_{GEOFF} of -8V.In case of a failure of the supply voltage, the gate-emitter connection is provided by a 10k Ω resistor to turn-off IGBTs.
- 4).The driver also comprised isolated DC/DC power.
- 5).The two IGBTs of the half bridge are interlocked in order to prevent them from being in the on-state simultaneously. The locking time between the turn-off signal for one IGBT and the release of the turn-on signal for the other one is 4us(>tdoff).The dead time adjusted from factory is 10us, and it can be adjustable by changing the resistor value on paralleling J3,K3 & J4,K4.
- 6).In the case of a short circuit both IGBTs are turned off immediately.An error memory prevents the IGBTs from being turned on again.The status of this memory has to be fed back to the control circuit via an open collector transistor(PSHI 27W).The error memory is only reset when both input signals are 0(>5us).
- 7).The nominal voltage of the power supply V_s is +15V.Its band of variation is from 14.4 to 15.6V.The current required is lower than 700mA (conditions: temperature=85°C, $V_s=15V$)Any undervoltage below +13V is monitored by "under-voltage protection circuit", and the IGBTs are turned off. An error signal is released.Overtoltage is not monitored.
- 8).The switching signals are transmitted by isolating pulse transformers.The isolation test voltage is 4kV AC/1 minute. The max.dv/dt rating between primary and secondary side is 75kV/us.
- 9).The input signals are COMS(+15V) compatible, for "PSHI27W" version. The inputs have a Schmitt trigger characteristic to suppress spurious pulse.The thresholds of the inputs are:
 $V_{IT+}=\text{min.}12.9V$
 $V_{IT-}=\text{max.}2.1V$

- 10).The operating temperature range is:
 Fiber optic interface PSHI27F: 0...+70°C
 Typ PSHI27W:Tamb=-25°C...+85°C.
- 11).The typical delay times and propagation times for signals are:
 turn-on: 1.0 + t_{TD} input to output
 turn-off: 1 us input to output
 Error: 1 us error input to error signal output
- 12).In order to optimize the turn-on and turn-off speed,resistor are connected,but external resistor R_G must be added mainly for modules in parallel,according to the conditions of the given application.External resistors R_G, R_{EX} and R_{CX} should be mounted on an additional circuit board near the paralleled modules.The R_{EX} assumes a value of 0.5 Ω and its functions is to reduce the load current to circulate by the auxiliary emitter which could make the emitter voltage against ground unbalance.The $R_{CX}=47 \Omega$,it has to be taken into account that creates an average of V_{CEsat} in case of short circuit for V_{CE} -monitoring(see Fig.2).

2. Circuit Block Diagram

The circuit block diagram as Fig.2

The system comprises the following components:

- 1).Input Buffers
 The input buffers have a Schmitt trigger characteristic and are CMOS(+15V) compatible.For the "F" version, there is the necessary optic input buffers and ERROR output circuit respectively, to perform the optical & electrical signals.
 - 2).Interlock circuit
 The interlock circuit prevents the IGBT turning on before the gate charge of the other IGBT is completely discharges.The interlock time is typically $t_{TD}=3.2us$.The dead time adusted from factory is 10us,and it can be adjustable by changing the resistor value R_{TD} on paralleling J3,K3 & J4,K4.Below table shows the corresponding relationship between R_{TD} and dead time.
- | R_{TD}
resistance value | Dead time | R_{TD}
resistance value | Dead time |
|------------------------------|-------------|------------------------------|-------------|
| 10k Ω | 0.9 μs | 68k Ω | 4 μs |
| 22k Ω | 1.8 μs | 100k Ω | 5 μs |
| 33k Ω | 2.5 μs | 330k Ω | 7.7 μs |
| 47k Ω | 3.2 μs | not bridged | 10 μs |
- Corresponding relationship between R_{TD} and dead time of jumper J3;K3,J4;K4
- 3).Short pulse suppression
 The short pulse suppression makes sure that only adequate trigger pulses are transmitted to the output flipflop. (<500ns short-pulse retrained)
 - 4).Error monitoring
 This circuit monitors pulses fed backwards via the pulse transformers.

5).Error momory

The error memory is triggered by the error monitoring circuit. The error memory blocks the turn-on pulses to both IGBTs simultaneously. Resetting is only possible when no pulses from the error monitoring are and both inputs are low level (>5us). At the same time, The output signal is fed to a terminal which is connected to the control circuit(open-collector-transistor PSHI 27W,an external pull-up transistor has to be provided on the cus tomers control board).

6).DC/DC-Converter

A high frequency DC/DC power supply used in external circuit to supply isolation power supply with output voltage: +15V/-8V. Power supply use full-bridge,filtering and stabilization circuit, drivers and controlled system can use same power supply(+15V), even if we are using more than one PSHI 27.

7).V_s-monitoring

The supply voltage V_s is monitored for its minimum value of 13V.If it falls below this value an error is monitored and the turn-on pulses for the IGBT are blocked.

8).Ferrite transformer

With a "FERRITE TRANSFORMER" the information between primary and secondary may flow in both directions and high levels of dv/dt(75kV/us) and high isolation voltage(AC4kV,1 min.).At the same time, it can also restrain the short-pulse signals below 500ns.The pulse transformer transmits the turn-on and turn-off signals for the IGBT. In the reverse direction the error signal from the V_{CE} monitoring is transmitted via the same transformer.

9).High-frequency voltage transformer

10).Rectifier & stabilizer for the auxilliary power supply

11).Power output

The output stage has a MOSFET pair which is able to source/sink up to 30A peak current to/from the gate improving the turn-on/off capability.According to the application (switching frequency and gate charge of the IGBT),different R_{Gon} and R_{Goff} must be selected. There is no R_{Gon} and R_{Goff} in driver. User need to install the gate resistor R_{Gon} and R_{Goff} onto a small piece of PCB near the IGBT gate,and the length between driver and IGBT should be as short as possible,flat cable must have the pairs of conductors twisted.

Please make sure that the total value of R_{Gon} & R_{Goff} not below 1.1 Ω in order to avoid damaging driver.

12).V_{CE} monitoring

"V_{CE} monitoring circuit" is responsible for short-circuit sensing. Due to the direct measurement of V_{CEstat} on the IGBT's collector, it blocks the output buffer (through the soft turn-off circuit) in case of short-circuit and sends a signal to the ERROR memory on the primary side.

The reference voltage V_{CEref} adjusted dynamically according to IGBT switch characteristics, and reset when IGBT turn-off. The V_{CEref} is not static but a dynamic reference which has an exponential shape starting at about 15 V and decreases to V_{CEstat} (determined by R_{CE}), with a time constant τ (controlled by C_{CE}) (see Fig.3).

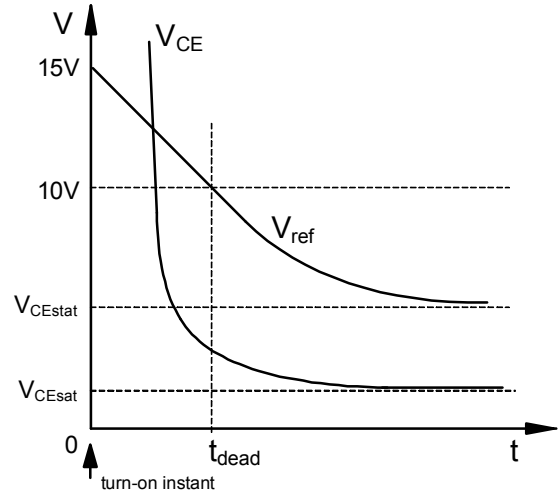

Fig.3 V_{ref} waveform of V_{CE} voltage monitor and V_{CE} waveform when IGBT starts to conduct

V_{CEstat} threshold is a static value of V_{CEref} which is controlled by resistor R_{CE}. It can be adjusted by resistor R_{CE} (J6,K6;J8,K8)to reach the maximum value as per IGBT's demand. V_{CEstat} >V_{CEsat} under nomal conditions, but will not exceed 10V.The decay time of V_{CEref} is determined by capacitor C_{CE} and resistor R_{CE}.It controls the dead time t_{dead} when IGBT just starts to conduct till V_{CEstat} monitoring starts.

To avoid a false failure indication when the IGBT just starts to conduct (V_{CE}>V_{CEref}), some decay time t_{dead} must be provided for the V_{CEref}. As the V_{CE} signal is internally limited at 10V, "V_{CE} monitoring circuit" will be trigger and cut off IGBT by "soft turn-off circuit" when V_{CEref} drops to 10V(ie.leave monitor dead area t_{dead}) and V_{CE} voltage rises above the reference voltage at any time(V_{CE}>V_{CEref}). The various different operating conditions are depicted in Fig.4.

The monitor sensitivity of "V_{CE} monitoring circuit" is adjusted by changing dead time t_{dead}.

PSHI 27 driver with V_{CEsat} =5.6V,R_{CE} =18kΩ, C_{CE} =330pF adjusted from factory.

Attention:

If this function is not used, for example during the experimental phase(not connect to IGBT), the V_{CE} MONITORING(X2.7,X3.7,X2.12,X3.12) must be connected with the EMITTER output(X2.1,X3.1,x2.8,X3.8) to avoid possible fault indication and consequent gate signal blocking.

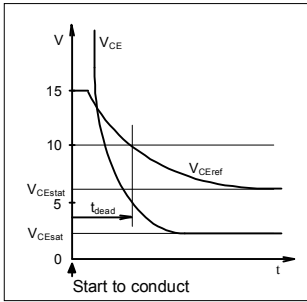

Fig.4a Usual case

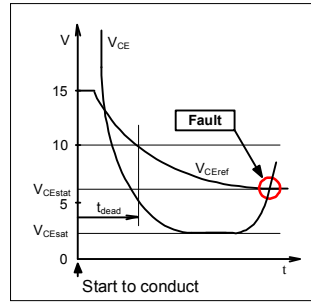

Fig.4b Short circuit during operation

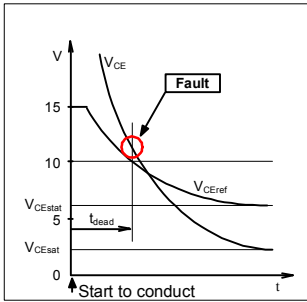

Fig.4c IGBT turns on too slowly or dead time is too short

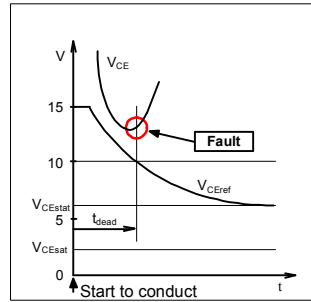

Fig.4d Short circuit during turn-on

13).Soft Turn-off

In case of a short circuit, it is better to switch off the circuit softly,to reduce over voltages which are induced in parasitic inductance,because of the high di/dt.This soft turn-off circuit improve IGBT's reliability which make IGBT suitable for higher DC voltage application.

14).Connection monitoring

This feature is very important to prevent damage because of no proper connection between driver and gate emitter.In this case it happens that the Gate-Emitter Capacitance is charged up and the Collector-Emitter Patch remains conductive,what causes a short circuit when the opposite switch is also switched on.The connection monitor sets the error memory in case of loose connection.

3. Input Interface Criterion

1).Input Signal Level (typ. PSHI27W)

Input PWM signals can be CMOS level, active-logic control (high level IGBT switch on).

X1.4 is up IGBT controlled signal, while X1.2 is bottom IGBT signal.

2).Error Output (typ.PSHI27W)

Fault signals output X1.3 is open collector output, high level active.Pin X1.3 is required to be connected through a pull-up resistor.The voltage of pull-up circuit should below 24V, and external power supply should below 6mA (see Fig 5).

3).Error Reset (typ.PSHI27W)

Install both X1.4 and X1.2 LOW at the same time for more than 5 us, error reset automatically(see Fig 5).

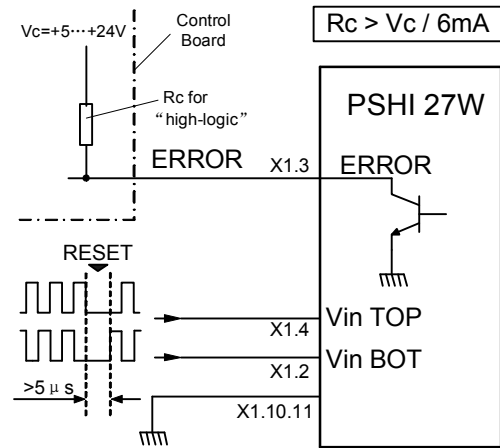

Fig.5 Driver status information ERROR and RESET

4).Connecting leads between Driver and Control Board (typ.PSHI27W)

The length between driver and control board should be kept short.If the length is below 50cm, connect with common flat cable is OK .If the length is 50-100cm, only CMOS level can be used for signal transmission, flat cable must have the pairs of conductors twisted or be shielded. If a shielded cable is used, it can be connected to pin X1.10,11.The connecting leads between driver and control board is not allowed to more than 1meter.For the application for strong interference environment or longer connecting, PSHI 27F with fiber optic interface should be selected.

5).Parelleling IGBTs

To get high power output, paralleling IGBTs is recommended.The typical PSHI 27 offers 2-pair IGBT paralleled, every pair only recommend 6pcs half-bridge modules paralleled at most.The parallel connection is recommended only by using IGBTs with homogeneous structure, that have a positive temperature coefficient resulting in a perfect current sharing without any external auxiliary element.Care must be considered to reach an optimized circuit and to obtain the total performance of the IGBT:The IGBTs must have independent values of R_{Gon} and R_{Goff} , and an auxiliary emitter resistor R_E as well as an auxiliary collector resistor R_C must also be used.The external resistors R_{GONX} , R_{GOFFX} , R_{EX} (0.5 Ω) and R_{CX} (47 Ω) should be mounted on an additional circuit board near the paralleled module.The cable length between additional circuit board and each IGBT should keep the same(see Fig.2).

4. Application/Handling

1).The CMOS inputs of the driver are extremely sensitive to overvoltage. Voltages higher than ($V_s + 0.3V$) or under-0.3V may destroy drivers. Therefore, the signal of control board must be observed for above mentioned demand,and not-used pins should be soldering bridged with GND in order to avoid un-equipped pins. Pay more attention to electrostatic breakdown.

Therefore the following EMC safety requiremnets

have to be observed:

- To make sure that the control signals do not comprise over volages exceeding the above values.
- Protection against static discharges during handling.

2).The connecting leads between the driver and the power module must be as short as possible, and should be twisted.

3).Any parasitic inductance should be minimized, turn-off over-voltage can be decreased by differenet snubber circuit.

4).When first operating a newly developed circuit low collector voltage and load current should be used in the beginning, and these values should be increased gradually,observing the turn-off behaviour of the free wheeling diodes and the turn-off voltage-spikes across the IGBT by means of the oscilloscope.Further the case temperature of the power module should be monitored.

When the circuit works correctly,short circuit tests can be made, starting again with low collector voltage.

5).It is important to feed any errors back to the control circuit and to switch the equipment off immediately in such events.Repeated turn-on of the IGBT into a short circuit with a frequency of several kHz may destroy the device.

6).Fig.6 shows the relationship between maximum operating frequency and charge per pulse.

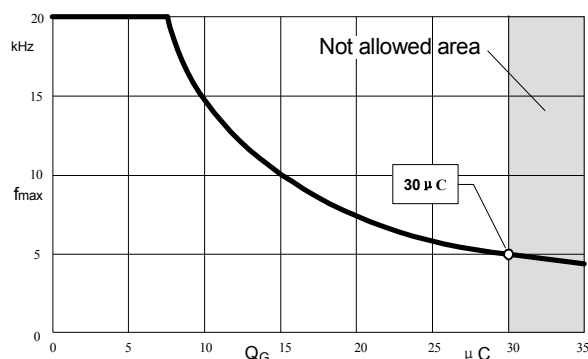

Fig.6 Relationship between maximum operating frequency and charge per pulse