

Three Phase Full Controlled Bridges

PSDT 110

$I_{dAV} = 110A$
 $V_{RRM} = 400-1600 V$

Preliminary Data Sheet

| V_{RSM} V_{DSM} | V_{RRM} V_{DRM} | Type |
|------------------------|------------------------|-------------|
| 500 | 400 | PSDT 110/04 |
| 900 | 800 | PSDT 110/08 |
| 1300 | 1200 | PSDT 110/12 |
| 1500 | 1400 | PSDT 110/14 |
| *1700 | *1600 | PSDT 110/16 |

* Delivery on request

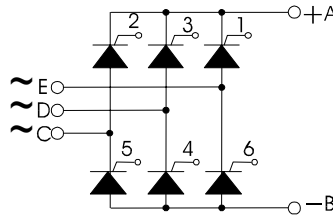

| Symbol | Test Conditions | Maximum Ratings |
|----------------|--|--------------------------|
| I_{dAV} | $T_C = 85^\circ C$ per module | 110 A |
| I_{TSM} | $T_{VJ} = 45^\circ C$ $t = 10 \text{ ms}$ (50 Hz), sine | 1150 A |
| | $V_R = 0$ $t = 8.3 \text{ ms}$ (60 Hz), sine | 1230 A |
| | $T_{VJ} = T_{VJM}$ $t = 10 \text{ ms}$ (50 Hz), sine | 1000 A |
| | $V_R = 0$ $t = 8.3 \text{ ms}$ (60 Hz), sine | 1070 A |
| $\int i^2 dt$ | $T_{VJ} = 45^\circ C$ $t = 10 \text{ ms}$ (50 Hz), sine | 6600 $A^2 s$ |
| | $V_R = 0$ $t = 8.3 \text{ ms}$ (60 Hz), sine | 6280 $A^2 s$ |
| | $T_{VJ} = T_{VJM}$ $t = 10 \text{ ms}$ (50 Hz), sine | 5000 $A^2 s$ |
| | $V_R = 0$ $t = 8.3 \text{ ms}$ (60 Hz), sine | 4750 $A^2 s$ |
| $(di/dt)_{cr}$ | $T_{VJ} = T_{VJM}$ repetitive, $I_T = 50 A$ $f = 400 \text{ Hz}$, $t_p = 200 \mu s$ $V_D = 2/3 V_{DRM}$ | 150 $A/\mu s$ |
| | $I_G = 0.3 A$ non repetitive, $I_T = 1/3 \cdot I_{dAV}$ $di_G/dt = 0.3 A/\mu s$ | 500 $A/\mu s$ |
| | $(dv/dt)_{cr}$ $T_{VJ} = T_{VJM}$ $V_{DR} = 2/3 V_{DRM}$ $R_{GK} = \infty$, method 1 (linear voltage rise) | 1000 $V/\mu s$ |
| P_{GM} | $T_{VJ} = T_{VJM}$ $t_p = 30 \mu s$ | $\leq 10 W$ |
| | $I_T = I_{TAVM}$ $t_p = 500 \mu s$ | $\leq 5 W$ |
| P_{GAVM} | | $\leq 0.5 W$ |
| V_{RGM} | | 10 V |
| T_{VJ} | | -40 ... + 125 $^\circ C$ |
| T_{VJM} | | 125 $^\circ C$ |
| T_{stg} | | -40 ... + 125 $^\circ C$ |
| V_{ISOL} | 50/60 HZ, RMS $t = 1 \text{ min}$ | 2500 V ~ |
| | $I_{ISOL} \leq 1 \text{ mA}$ $t = 1 \text{ s}$ | 3000 V ~ |
| M_d | Mounting torque (M6) | 5 Nm |
| | Terminal connection torque (M6) | 5 Nm |
| Weight | typ. | 270 g |

Features

- Package with screw terminals
- Isolation voltage 3000 V~
- Planar glasspassivated chips
- Low forward voltage drop
- UL registered, E 148688

Applications

- Heat and temperature control for industrial furnaces and chemical processes
- Lighting control
- Motor control
- Power converter

Advantages

- Easy to mount with two screws
- Space and weight savings
- Improved temperature and power cycling capability
- High power density

Package, style and outline

Dimensions in mm (1mm = 0.0394")

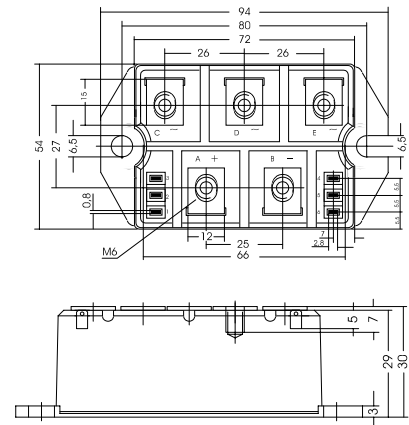

| Symbol | Test Conditions | Characteristic Value | |
|------------|--|------------------------|---------------|
| I_D, I_R | $T_{VJ} = T_{VJM}, V_R = V_{RRM}, V_D = V_{DRM}$ | ≤ 5 mA | |
| V_T | $I_T = 200A, T_{VJ} = 25^\circ C$ | ≤ 1.75 V | |
| V_{TO} | For power-loss calculations only ($T_{VJ} = T_{VJM}$) | 0.85 V | |
| r_T | | 6 mΩ | |
| V_{GT} | $V_D = 6V$ | $T_{VJ} = 25^\circ C$ | ≤ 1.5 V |
| | | $T_{VJ} = -40^\circ C$ | ≤ 1.6 V |
| I_{GT} | $V_D = 6V$ | $T_{VJ} = 25^\circ C$ | ≤ 100 mA |
| | | $T_{VJ} = -40^\circ C$ | ≤ 200 mA |
| V_{GD} | $T_{VJ} = T_{VJM}, V_D = 2/3 V_{DRM}$ | ≤ 0.2 V | |
| I_{GD} | $T_{VJ} = T_{VJM}, V_D = 2/3 V_{DRM}$ | ≤ 5 mA | |
| I_L | $T_{VJ} = 25^\circ C, t_p = 30\mu s$ | ≤ 450 mA | |
| | $I_G = 0.3A, di_G/dt = 0.3A/\mu s$ | | |
| I_H | $T_{VJ} = 25^\circ C, V_D = 6V, R_{GK} = \infty$ | ≤ 200 mA | |
| t_{gd} | $T_{VJ} = 25^\circ C, V_D = 1/2 V_{DRM}$ | ≤ 2 μs | |
| | $I_G = 0.3A, di_G/dt = 0.3A/\mu s$ | | |
| t_q | $T_{VJ} = T_{VJM}, I_T = 20A, t_p = 200\mu s, V_R = 100V$ | 150 μs | |
| | $-di/dt = 10A/\mu s, dv/dt = 15V/\mu s, V_D = 2/3 V_{DRM}$ | | |
| R_{thJC} | per thyristor; sine 180°el | 0.65 K/W | |
| | per module | 0.108 K/W | |
| R_{thJK} | per thyristor; sine 180° el | 0.8 K/W | |
| | per module | 0.133 K/W | |
| d_s | Creeping distance on surface | 10.0 mm | |
| d_A | Creeping distance in air | 9.4 mm | |
| a | Max. allowable acceleration | 50 m/s ² | |

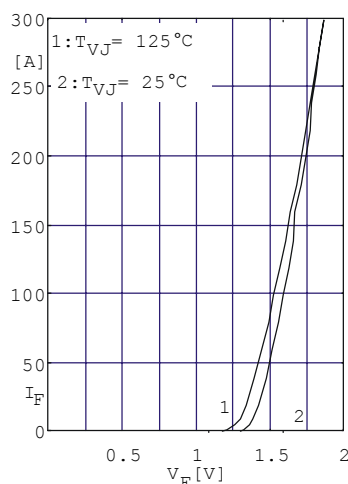

Fig. 1 Forward current vs. voltage drop per diode or thyristor

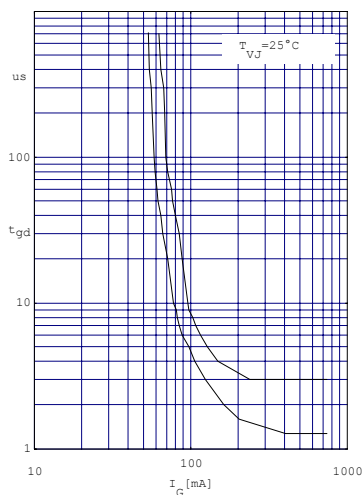

Fig. 2 Gate trigger delay time

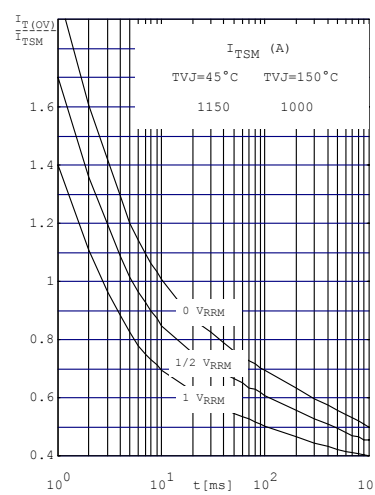

Fig. 3 Surge overload current per diode (or thyristor) I_{FSM} , I_{TSM} : Crest value t : duration

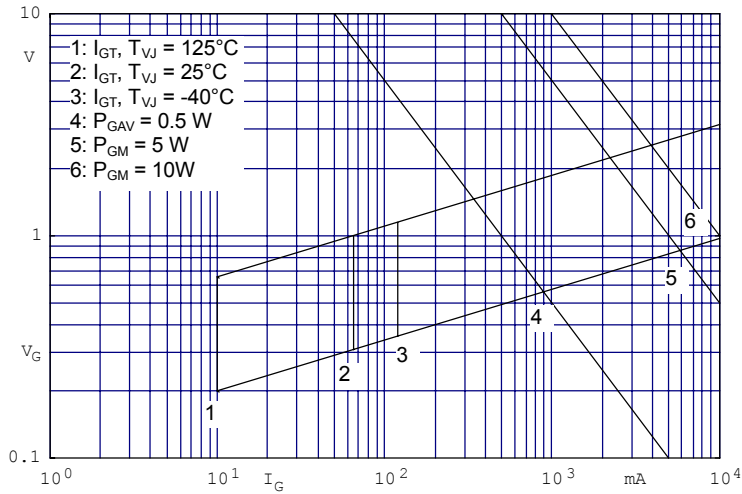

Fig.4 Gate trigger characteristic

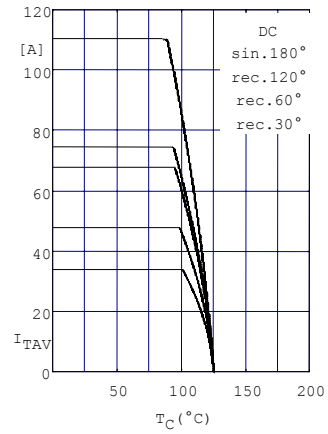

Fig.5 Maximum forward current at case temperature

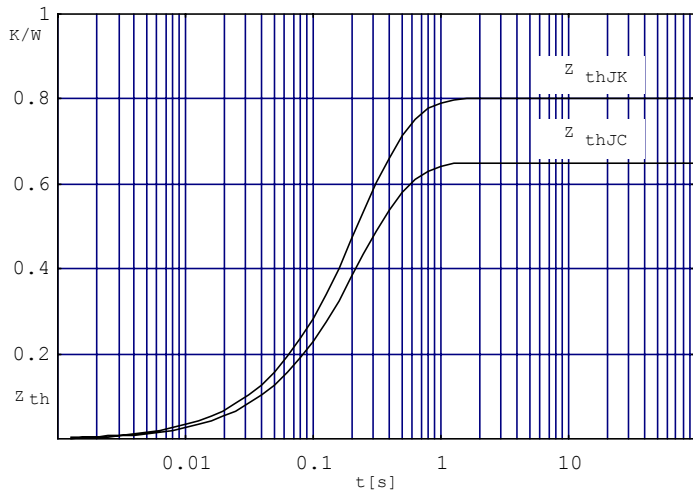

Fig.6 Transient thermal impedance per thyristor or diode (calculated)

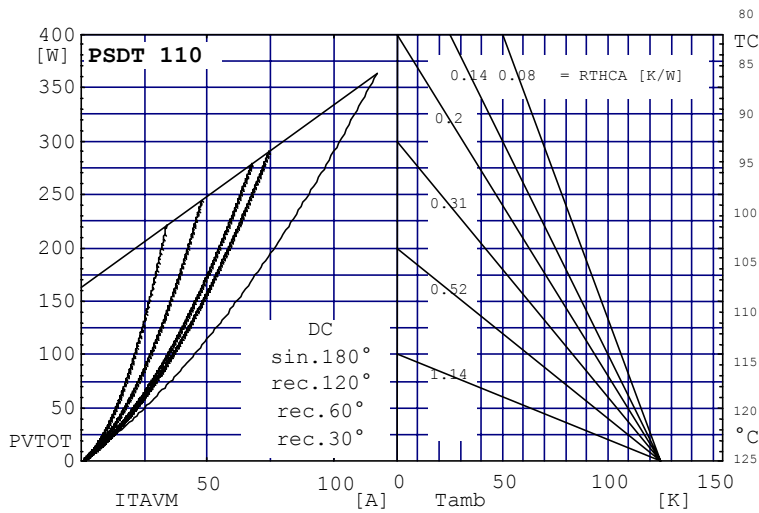

Fig. 7 Power dissipation vs. direct output current and ambient temperature